

FOR CONSTRUCTION - 1/5/2019

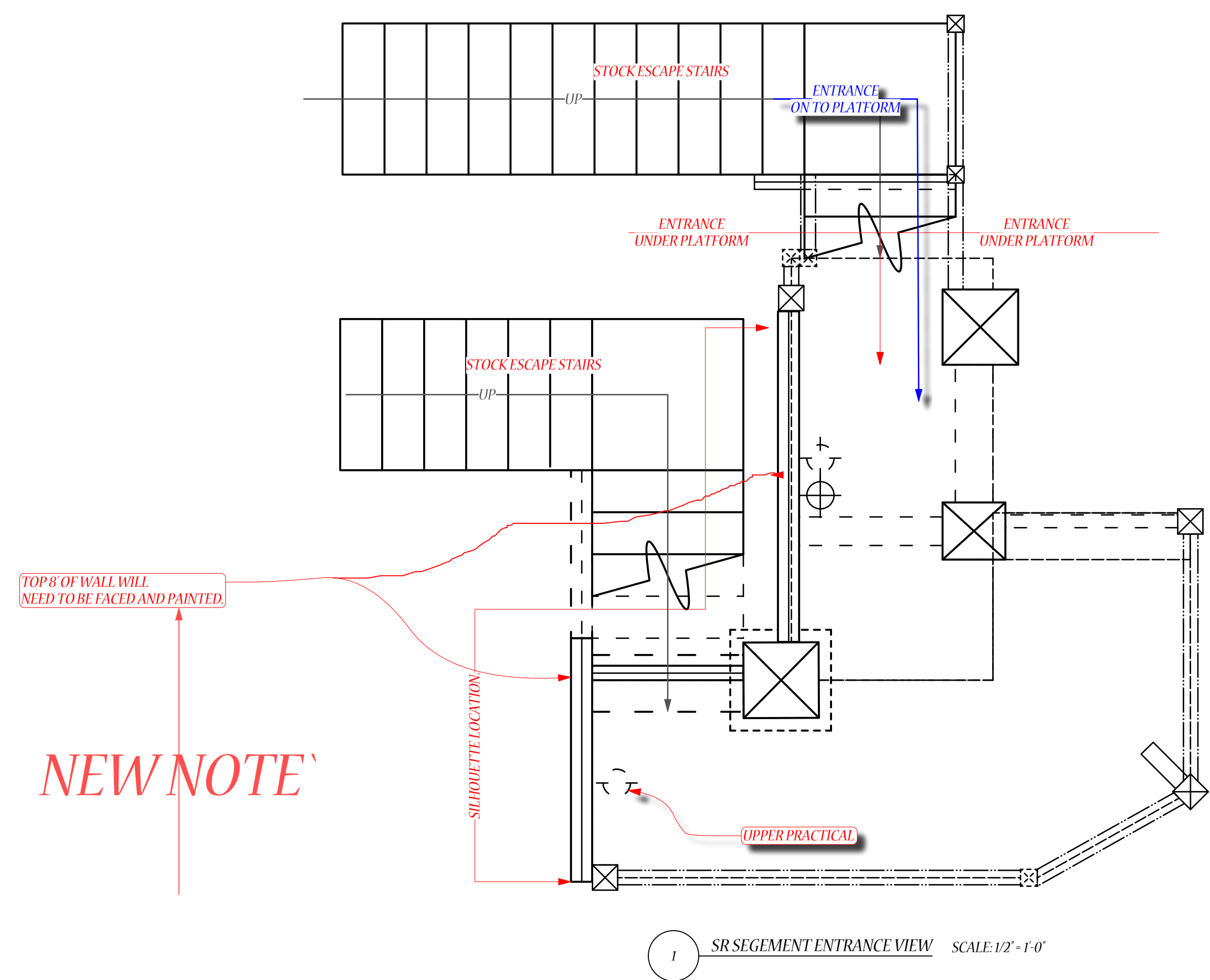

1 SR SEGMENT ENTRANCE VIEW SCALE: 1/2"=1'-0"

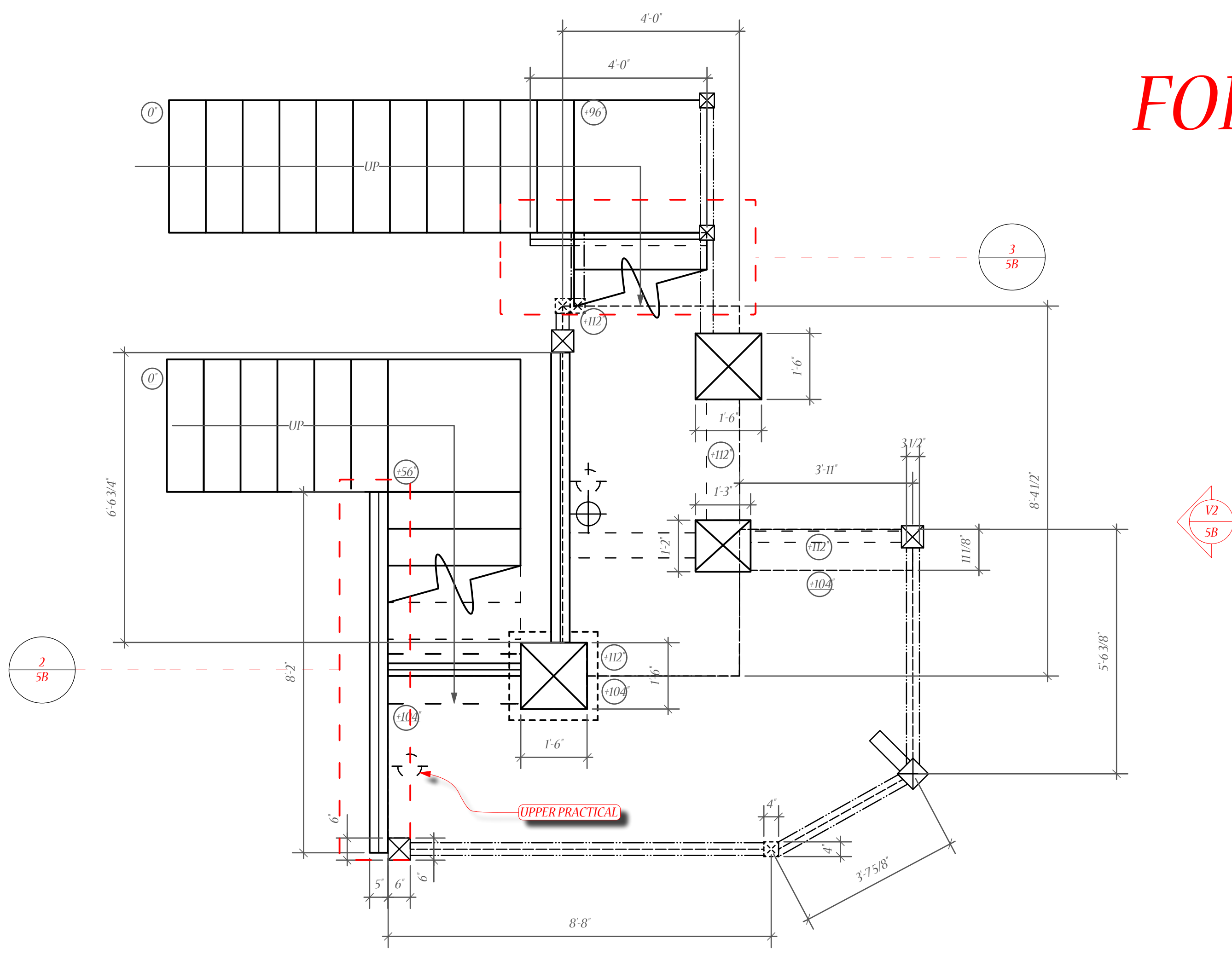

2 SR SEGMENT DETAIL VIEW SCALE: 1/2"=1'-0"

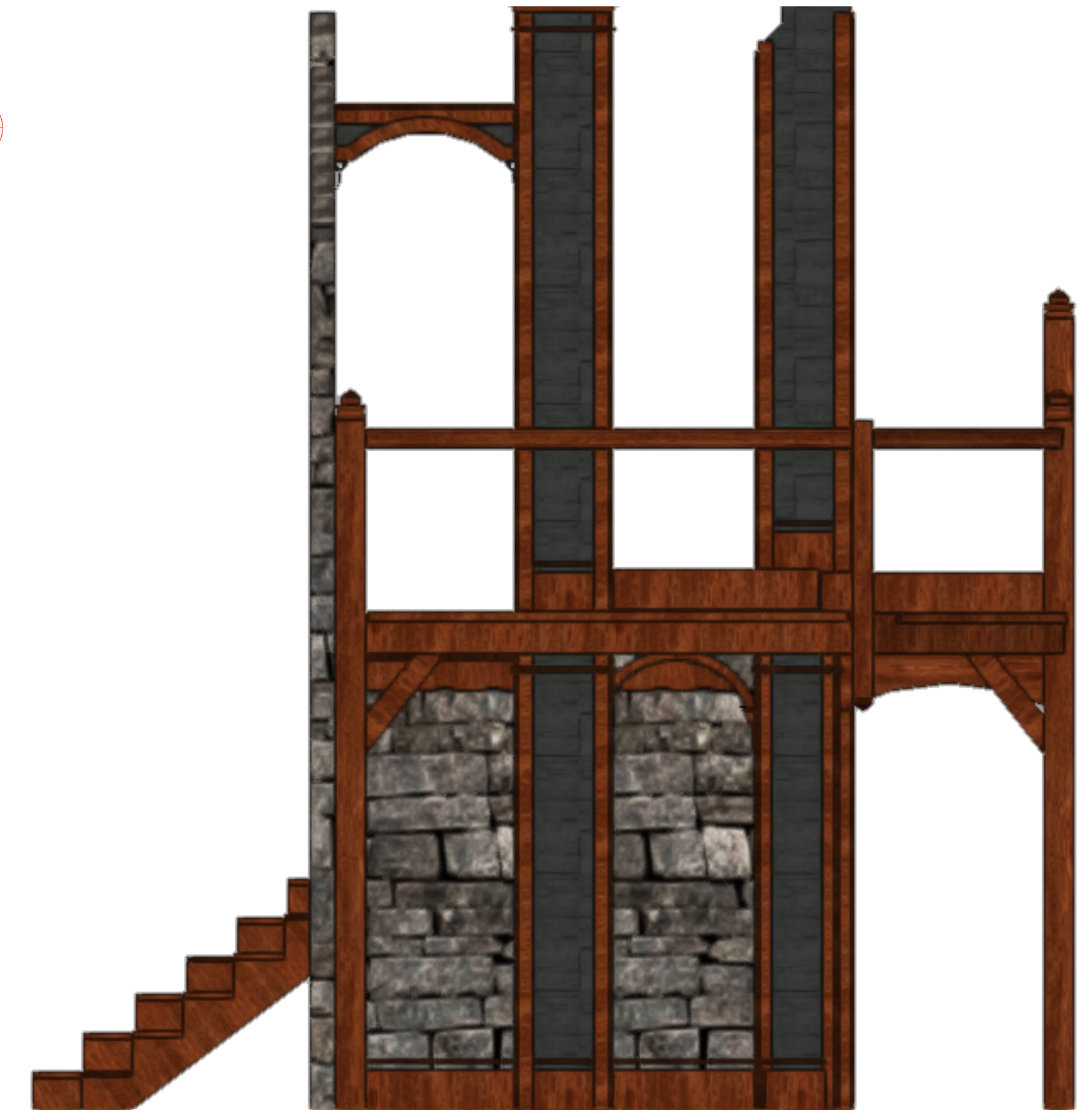

3 RENDERED FRONT VIEW Scale: 1/2"=1'-0"

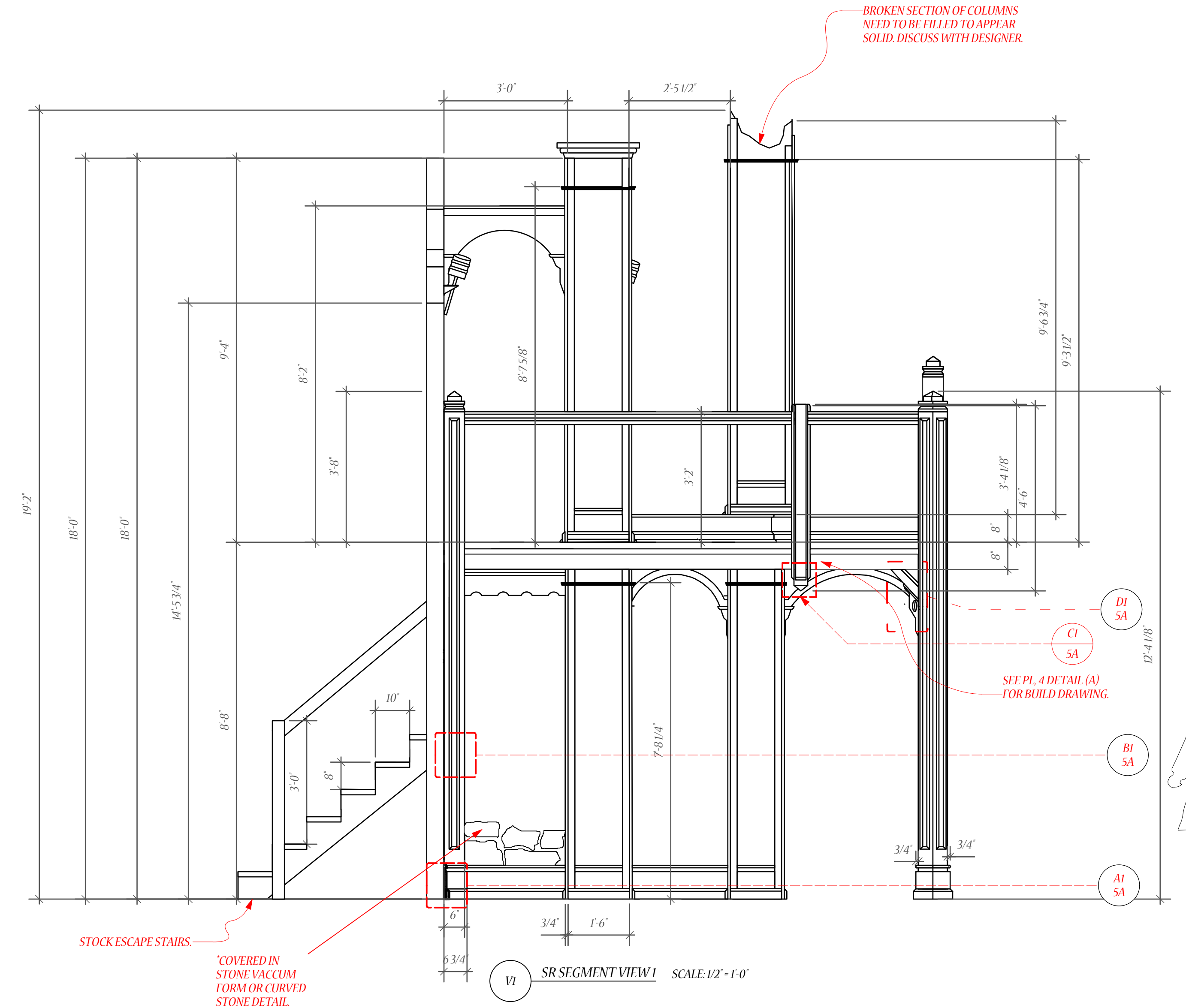

19 SR SEGMENT VIEW SCALE: 1/2"=1'-0"

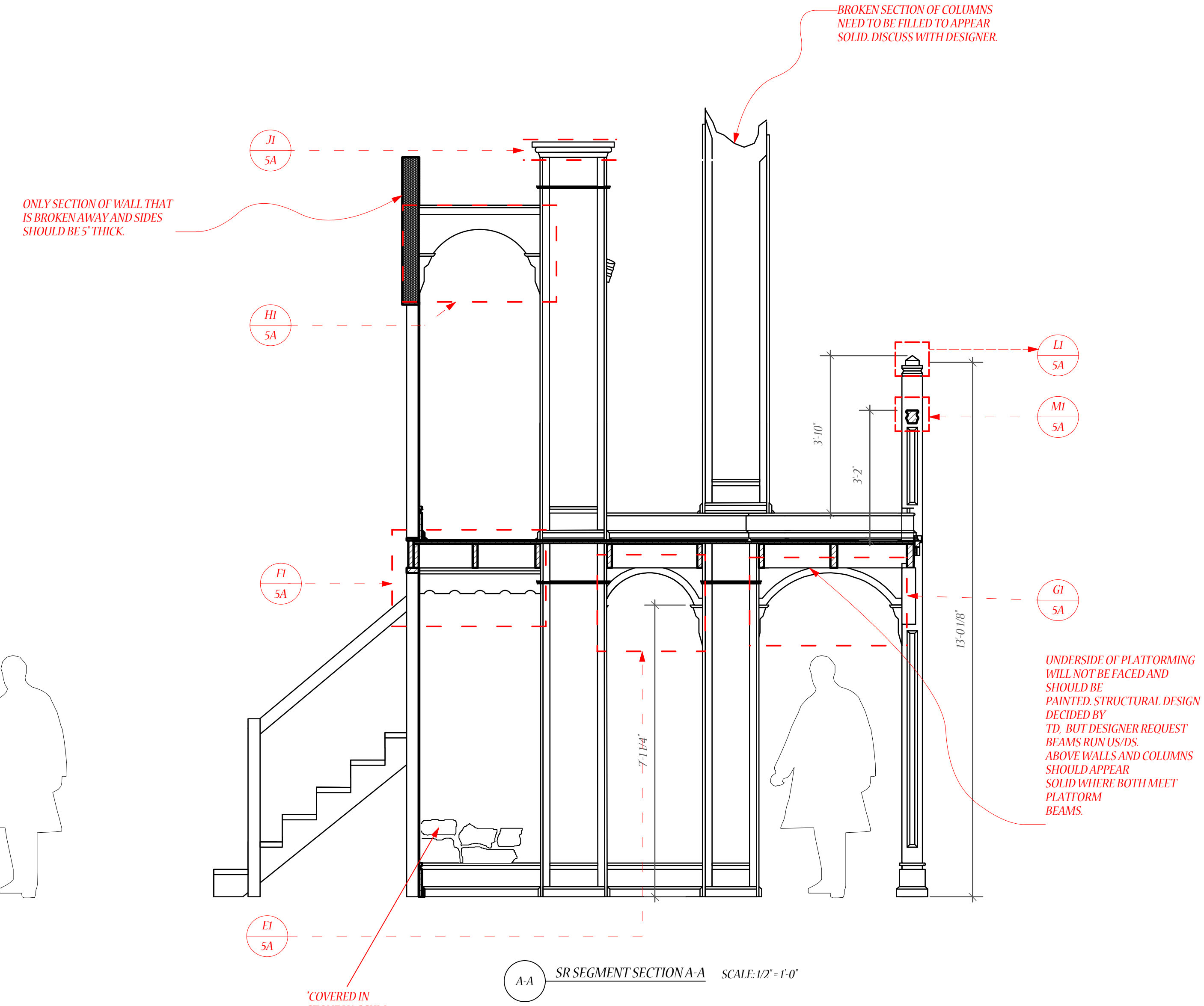

AA SR SEGMENT SECTION A-A SCALE: 1/2"=1'-0"



C DETAIL (C) RAILING POST DETAIL Scale: 2"=1'-0"

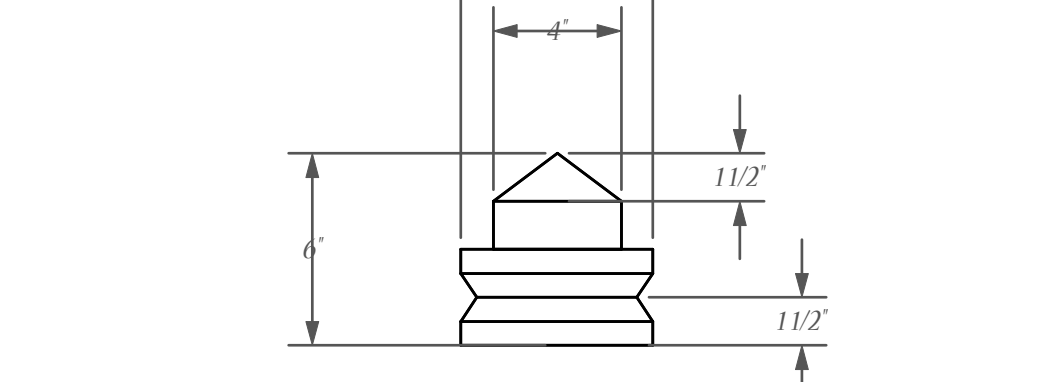

L DETAIL (L) POST TOP DETAIL Scale: 2"=1'-0"

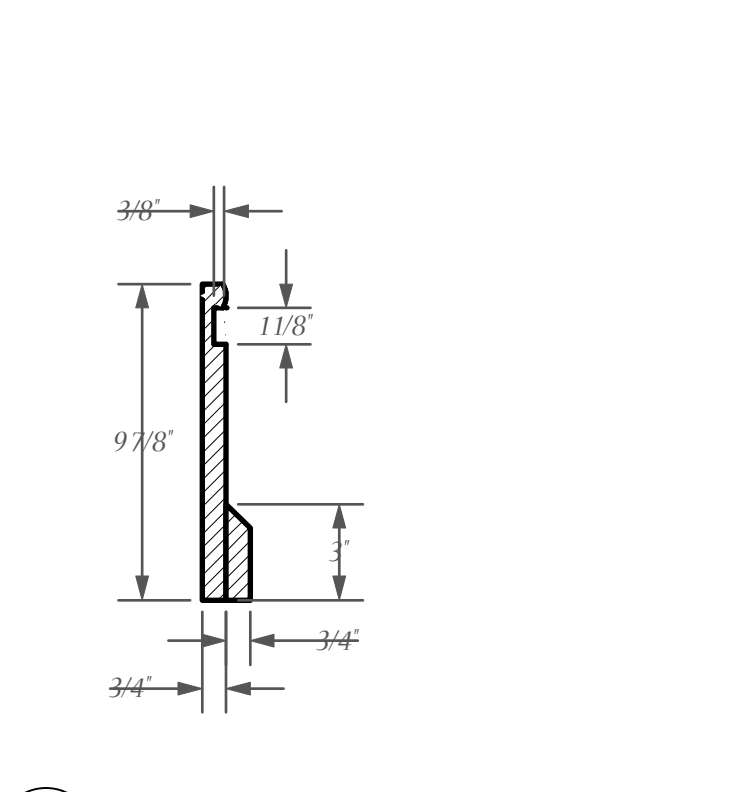

A DETAIL (A) 1ST FLOOR BASE Scale: 2"=1'-0"

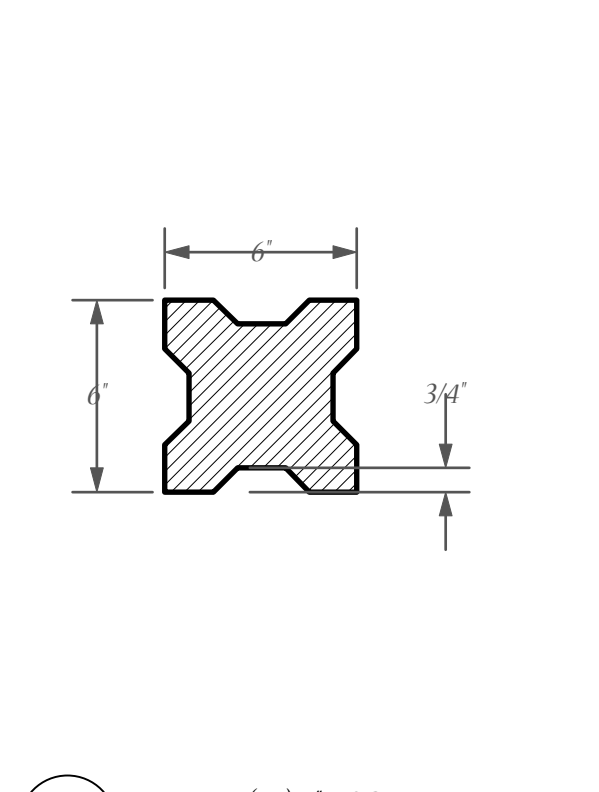

B DETAIL (B) 6 POST Scale: 2"=1'-0"

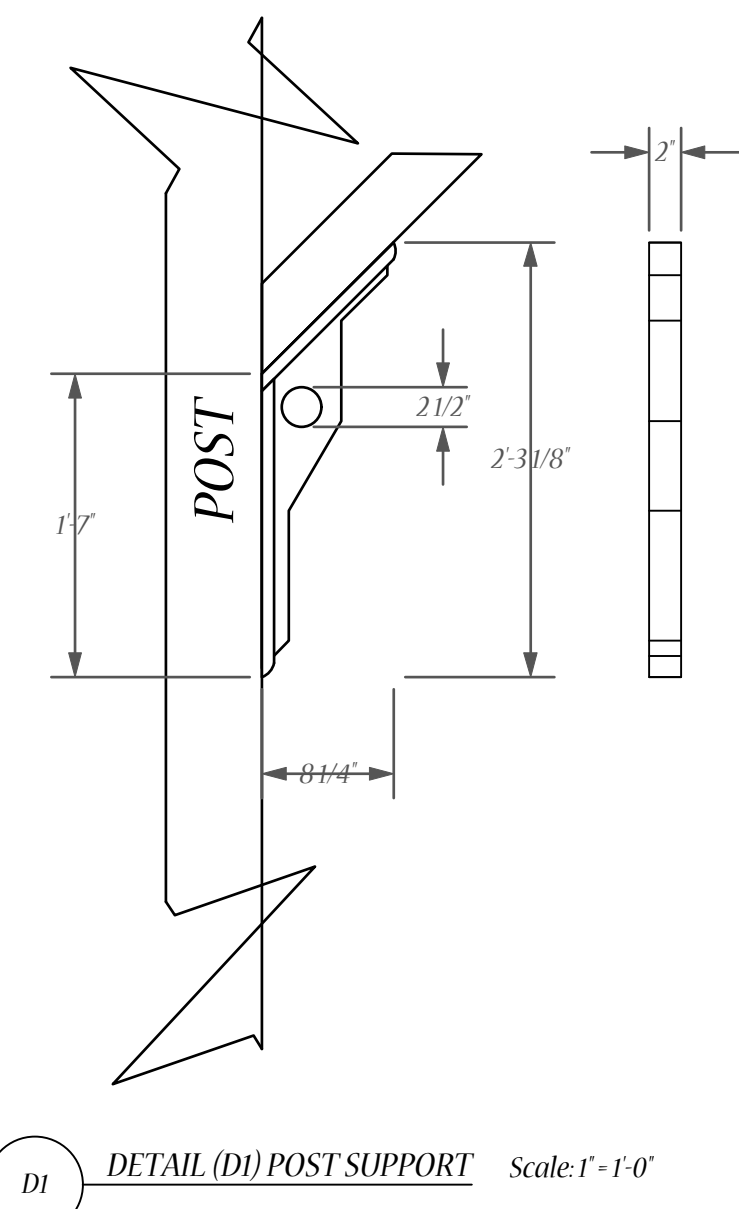

D DETAIL (D) POST SUPPORT Scale: 1"=1'-0"

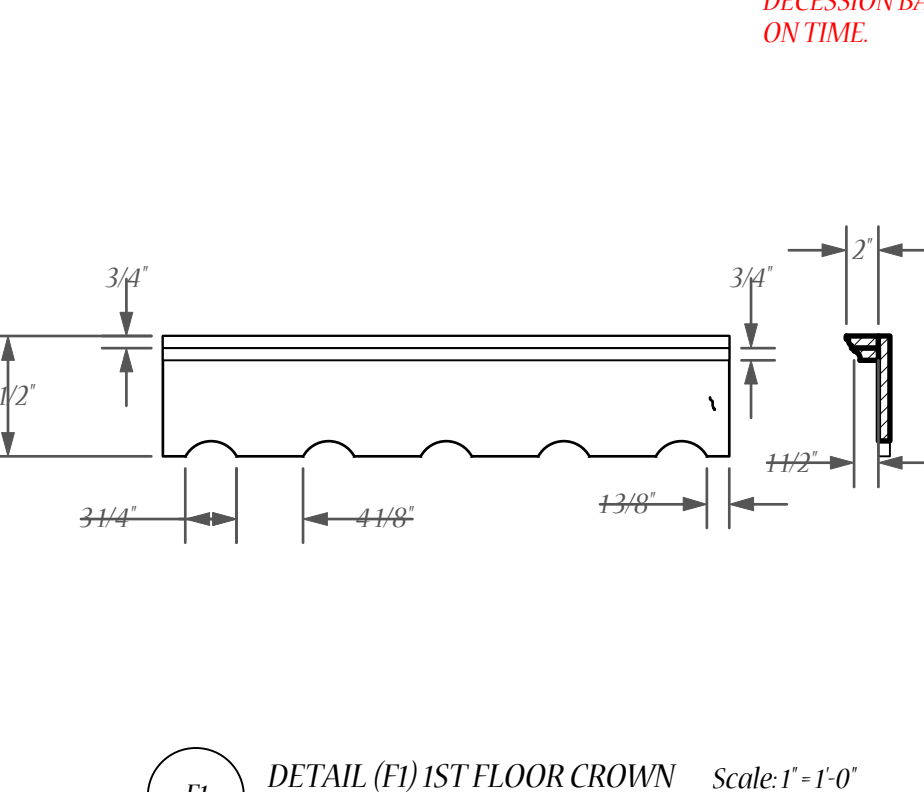

F DETAIL (F) 1ST FLOOR CROWN Scale: 1"=1'-0"

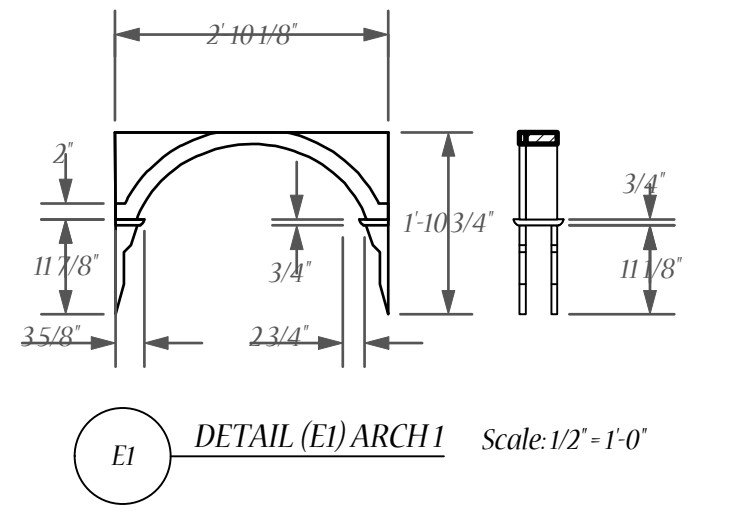

E DETAIL (E) ARCH Scale: 1/2"=1'-0"

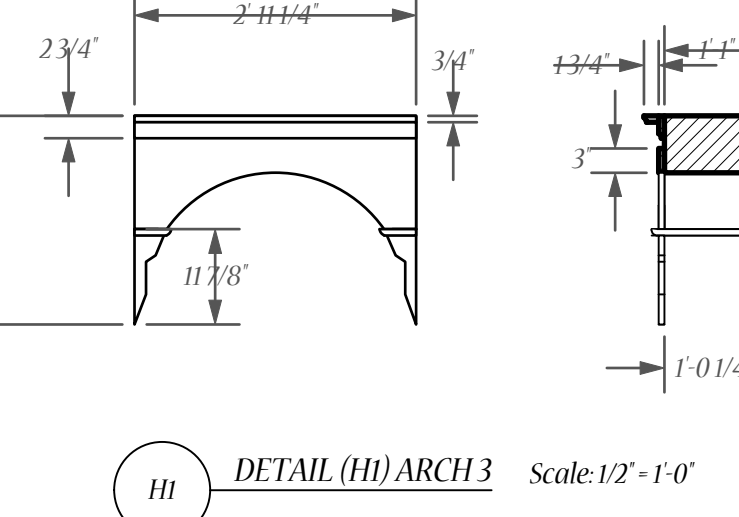

H DETAIL (H) ARCH Scale: 1/2"=1'-0"

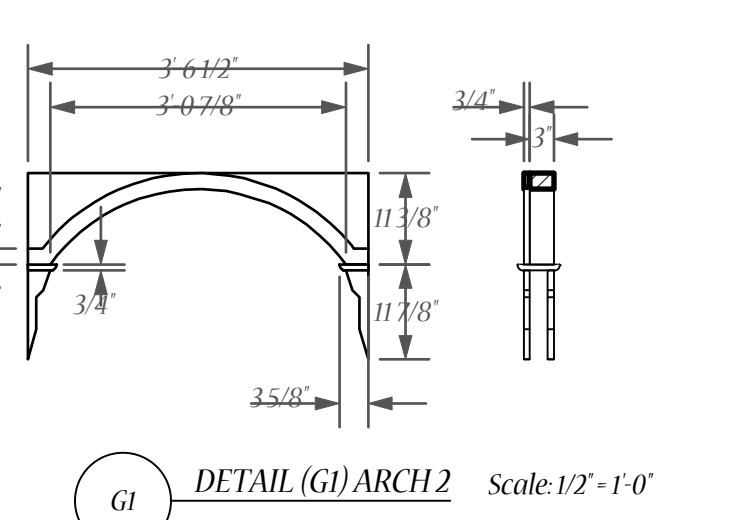

G DETAIL (G) ARCH Scale: 1/2"=1'-0"

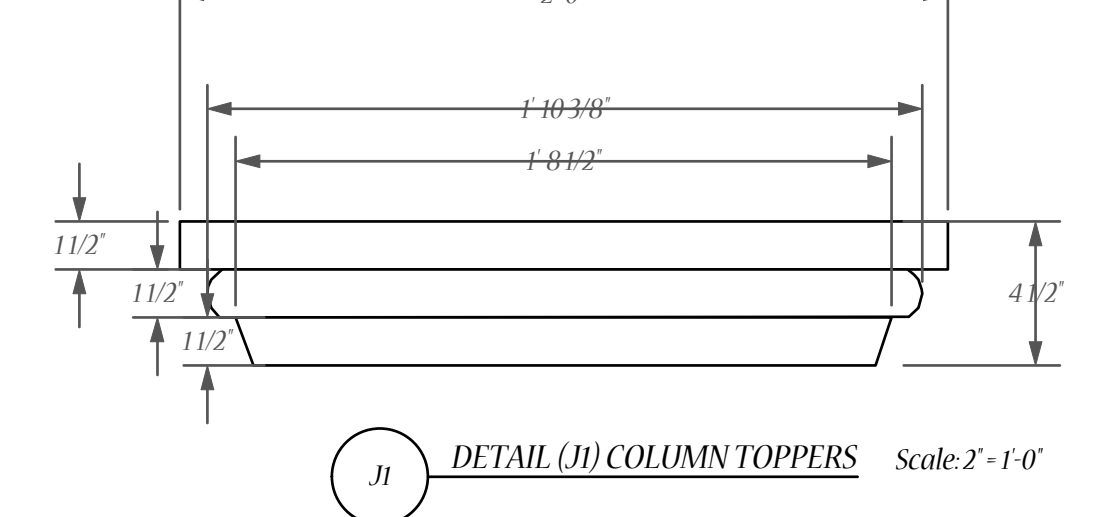

J DETAIL (J) COLUMN TOPPERS Scale: 2"=1'-0"

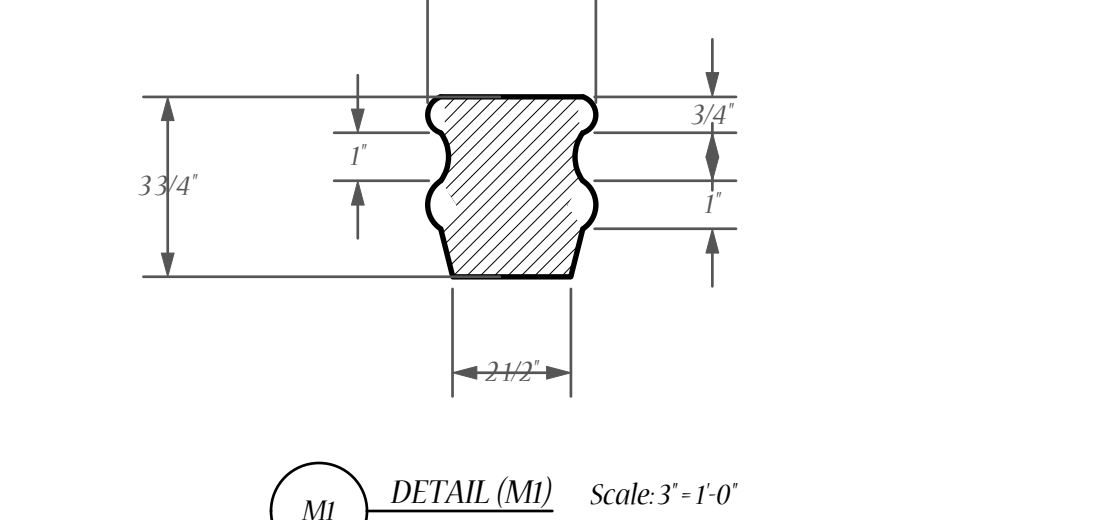

M DETAIL (M) Scale: 2"=1'-0"

MACBETH

BY: WILLIAM SHAKESPEARE
DIRECTOR: Miranda McCree
SCENIC DESIGNER: Justen N. Locke
TECHNICAL DIRECTOR: Elliott Hays Wehle
COSTUME DESIGNER: Rainy Edwards
SOUND DESIGNER: Dong Korntrager
LIGHTING DESIGNER: Justen N. Locke
PROJECTIONS DESIGNER: BREKIN BERLIN

DWG. BY: JNL

DWG. DATE: 1.8.19

SR WALL SEGMENT

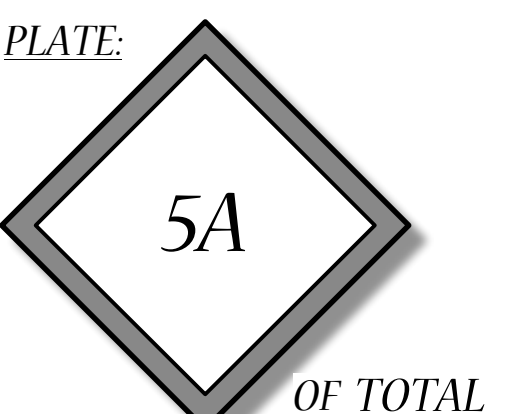

SCALE: 1/2"=1'-0"

REV #	DATE	NOTE
A	1.4.19	PRELIM
B	1/5/2019	PRELIM
C	123.19	EDITED DETAIL

NOTES:

- THIS IS A BUILD DRAFTING.
- PLEASE ROUND ALL MEASUREMENTS TO THE WHOLE INCH WHERE APPLICABLE.
- ALL WALLS THAT MEASURE 3 1/2" CAN BE ADJUSTED TO STOCK WIDTH SIZE DETERMINED BY TD.
- WALLS THAT ARE MEASURED TO BE 5" THICK ONLY HAS TO BE 5" ALONG SIDES AND TOPS.
- DOORS ARE ALL FUNCTIONAL AND HARDWARE WILL BE CHOSEN BY DESIGNER. (PLEASE GIVE \$200 ALLOWANCE FOR HARDWARE.)
- ALL PRACTICALS WILL BE A COLLABORATION BETWEEN PROPS AND SCENIC. PLEASE DISCUSS WITH DESIGNER.
- SURFACE TEXTURE IS STILL BEING DISCUSSED BETWEEN SD AND PROJECTIONS DESIGNER.
- ANY SECTION OF WALLS THAT ARE NOT USED FOR SILHOUETTE PLEASE FACE WITH 3/16" LAUAN AND VACUUM FORM STONES.
- DISCUSS STONE PATTERN WITH DESIGNER.